



# C&D 12-120 GEL

## Valve Regulated Lead Acid Battery – Gel Type

### APPLICATIONS

- Telecommunication systems
- Uninterruptible power supplies
- Electric Power Systems
- Electronic test equipment
- Control equipment
- Medical equipment
- Fire & security systems
- Solar systems
- Wine energy systems
- Other standby, cyclic and outdoor applications

### FEATURES

- 10 years design life at floating use.
- Gel electrolyte technology for better wide temperature range performance, prevention from thermal runaway, insure reliability and safety.
- Proprietary Pb-Ca Alloy – minimizing grid growth, reducing gassing, and extending battery life
- Flame arresting one-way pressure vents for safety and improved life
- Gas recombination efficiency of up to 99% for freedom from electrolyte maintenance
- Good deep cycle performance
- Lower self-discharge rate (Less than 3% per month)
- Not restricted for air transport – Complies with IATA/ICAO Special Provision A67.
- Not restricted for surface transport – classified as non-hazardous material as related to DOT-CFR Title 49 parts 171-189
- Not restricted for water transport – classified as non-hazardous material per IMDG Amendment 27

### SPECIFICATIONS

Cells Per Unit	Voltage Per Unit	Weight	Capacity 20°C to 1.80V per cell	Max. Discharge Current	Internal Resistance
6	12V	41.5 Kg	119 Ah @10hr rate	1340 A (5 sec)	6 (mΩ)

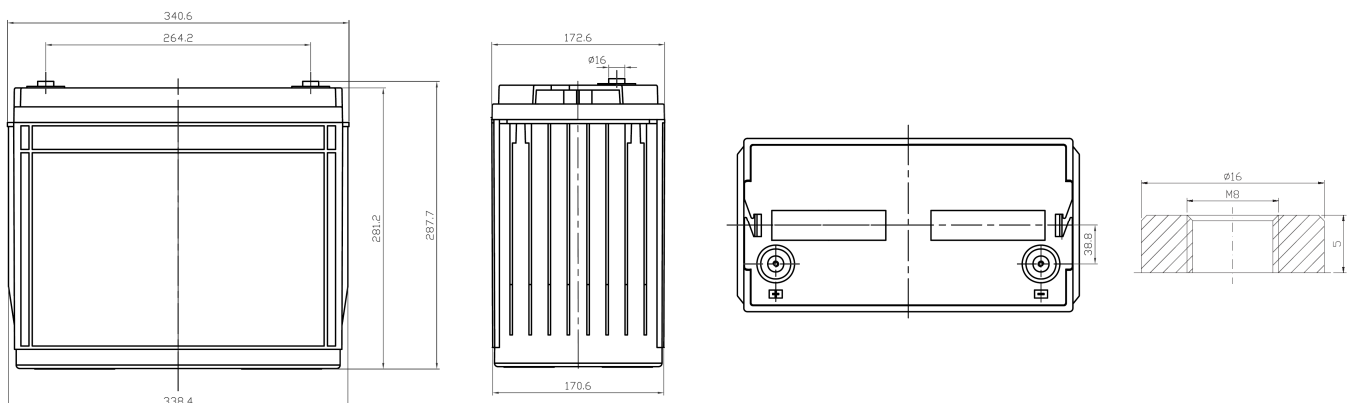

\*All dimensions in inches and (millimeters). All dimensions are for reference only. Contact a C&D Representative for complete dimensional information.

## Specifications

Operating Temperature Range	Discharge: -40°C to 60°C Charge: -20°C to 50°C
Nominal Operating Temperature Range	25°C ± 5 °C
Float Charging Voltage	13.6 to 13.8VDC/unit average at 25°C
Recommended Maximum Charging Current Limit	26.8A
Equalize charge and cycle service voltage	14.2 to 14.4 VDC/unit average at 25°C
Self Discharge	Batteries can be stored for 6 months at 25°C. Self-discharge ratio less than 3% per month at 25°C. Please charge batteries before using.
Terminal:	Inserted terminal to accept M8 bolt
Container Material	ABS (UL94 HB, V-0 optional)

Constant Current Discharge Table - Amps @ 25°C (77°F)

Operating Time to End Point Voltage

End Voltage Per Cell	5min	10min	15min	30min	1hr	2hr	3hr	4hr	5hr	8hr	10hr	20hr
1.85	226.8	171.9	151.6	114.5	71.4	43.3	29.9	24.4	20.1	13.8	11.9	6.1
1.80	262.6	190.1	167.1	121.1	75.2	45.3	31.2	25.6	21.0	14.5	12.3	6.5
1.75	287.6	206.1	179.2	125.4	77.0	46.1	32.1	26.2	21.4	14.7	12.4	6.6
1.70	316.6	220.7	186.1	127.4	77.8	46.5	32.2	26.5	21.6	14.8	12.5	6.8
1.67	326.2	228.8	189.0	127.3	78.5	46.8	32.5	26.6	21.7	14.9	12.6	6.9
1.60	336.0	240.4	193.0	129.3	78.8	47.2	32.6	26.7	21.9	15.1	12.7	7.0

Constant Power Discharge Table - Watts Per Cell @ 25°C (77°F)

Operating Time to End Point Voltage

End Voltage Per Cell	5min	10min	15min	30min	1hr	2hr	3hr	4hr	5hr	8hr	10hr	20hr
1.85	423.2	323.7	282.8	220.5	140.0	86.5	59.7	48.8	40.1	27.7	23.8	12.2
1.80	476.3	353.9	310.6	232.5	146.2	89.8	62.4	51.2	42.0	28.9	24.5	13.0
1.75	517.0	379.5	332.2	240.2	149.0	91.0	64.2	52.4	42.7	29.4	24.7	13.3
1.70	561.2	402.7	344.2	243.6	150.3	91.6	64.4	52.9	43.2	29.6	25.0	13.5
1.67	567.7	413.7	348.1	242.9	151.5	92.2	64.7	53.0	43.4	29.8	25.2	13.8
1.60	579.1	426.7	353.8	245.7	151.9	92.7	64.7	53.1	43.5	30.0	25.4	14.0

Cyclic Performance Curve

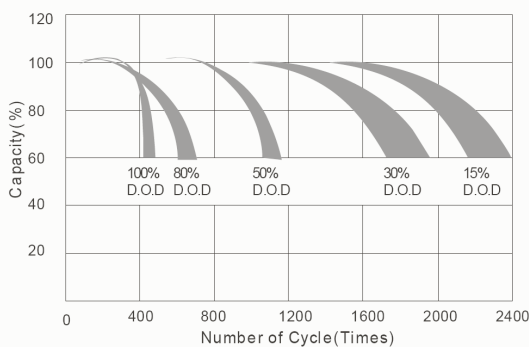

Discharge Characteristic Curve

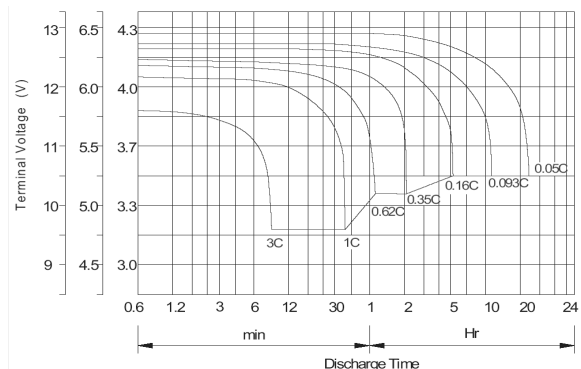

\* All data shall be changed without prior notice, C&D reserves the right to explain and update the information contained hereinto.